

PRE-INSTALLATION INSPECTION

THANK YOU FOR THE PURCHASE OF YOUR ROHN PRODUCT. WE ARE EXCITED THAT YOU CHOOSE ROHN TO SUPPLY YOU WITH A QUALITY PRODUCT. IN ORDER TO COMMUNICATE EFFECTIVELY, ELIMINATE ERRORS AND PROVIDE A SMOOTH INSTALLATION EXPERIENCE, IT IS IMPORTANT FOR THE INSTALLER TO PERFORM A PRE-INSTALLATION INSPECTION OF ALL COMPONENTS/PARTS ASSOCIATED WITH YOUR ORDER. PRIOR TO THE INSTALLATION, THE FOLLOWING INSPECTIONS ARE REQUIRED:

- UPON RECEIPT OF SHIPMENT, ALL PARTS/MATERIALS MUST BE INVENTORIED. THIS INCLUDES ALL TOWERS, MONOPOLES, GUYED MASTS, ANCHOR RODS & TEMPLATES, MOUNTS OR OTHER PRODUCTS THAT ARE DELIVERED TO A CONTRACTOR'S OFFICE, JOB SITE OR SOME OTHER AGREED UPON DESTINATION.
- IF THERE ARE PARTS THAT ARE FABRICATED INCORRECTLY AND THE PARTS WERE NOT EASILY DETECTABLE DURING THE PRE-INSTALLATION INSPECTION, ROHN MUST BE NOTIFIED IMMEDIATELY UPON IDENTIFICATION OF THE PARTS. IN ADDITION, PICTURES MUST BE TAKEN OF THE ISSUES AND SENT TO ROHN IMMEDIATELY.
- IT IS IMPORTANT TO VERIFY THE ASSEMBLY DRAWINGS AND ANCHOR ROD LAYOUT DRAWINGS ARE RECEIVED WITH THE DELIVERY, WHEN ANCHOR RODS ARE TO BE INSTALLED. IN ADDITION, IT IS IMPORTANT TO VERIFY THE ANCHOR ROD TEMPLATE PART NUMBERS MATCH THE DESIGNATED PART NUMBERS ON THE ANCHOR ROD LAYOUT DRAWING. IF THERE ARE DISCREPANCIES, NOTIFY ROHN IMMEDIATELY. ROHN WILL NOT BE RESPONSIBLE FOR CHARGES ASSOCIATED WITH INSTALLING THE WRONG SIZE ANCHOR RODS, THE WRONG NUMBER OF ANCHOR RODS OR THE INCORRECT ANCHOR ROD ORIENTATION.
- TRIAL ASSEMBLY OF COMPONENTS ON LEVEL GROUND IS RECOMMENDED PRIOR TO ERECTION TO DETERMINE THE PROPER ASSEMBLY SEQUENCE.
- IF PART SHORTAGES OR DAMAGED MATERIAL ARE FOUND, ROHN MUST BE NOTIFIED IMMEDIATELY TO ALLOW ROHN TIME TO REPAIR OR EXPEDITE NEW PARTS/MATERIALS TO THE JOB SITE.
- INDIVIDUAL BOLT ORIENTATION (NUT UP OR DOWN) IS DISCRETIONARY UNLESS OTHERWISE NOTED.
- ROHN WILL NOT BE RESPONSIBLE FOR EXCESS CHARGES INCLUDING CRANE CHARGES, DRILLING RIG CHARGES, EQUIPMENT CHARGES, CREW CHARGES AND MOBILIZATION CHARGES.
- IF YOU HAVE ANY QUESTIONS, PLEASE CONTACT THE APPROPRIATE ROHN SALES REP/MANAGER AT (309) 566-3000.

FILE NO.				
ROHN				
REVISIONS				
REV.	DESCRIPTION	DWN	CHK	APP
1	ADDED 4TH & 6TH BULLET DATE: 06/12/23	JDM	SY	SY
 PO BOX 5999 PEORIA, IL 61601-5999 TOLL FREE 800-727-ROHN				
<small>THIS DRAWING IS THE PROPERTY OF ROHN. IT IS NOT TO BE REPRODUCED, COPIED OR TRACED IN WHOLE OR IN PART WITHOUT OUR WRITTEN CONSENT.</small>				
PRE-INSTALLATION INSPECTION FORM NUMBER: FM060				
DWN:	CHK'D:	DATE:		
JHY	JDM	09/03/2019		
ENGR:	SHEET #:		1 OF 1	
SY				
PRJ. ENGR:	PRJ. MANG'R:			
DRAWING NO:				REV:
FM060				1

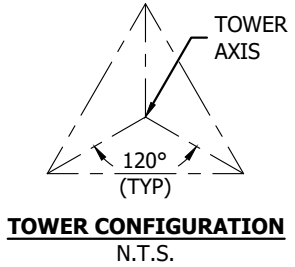
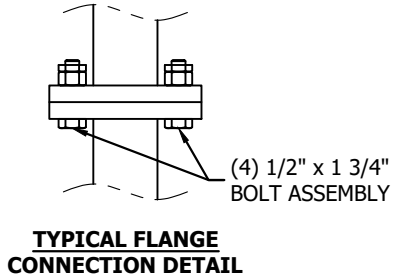
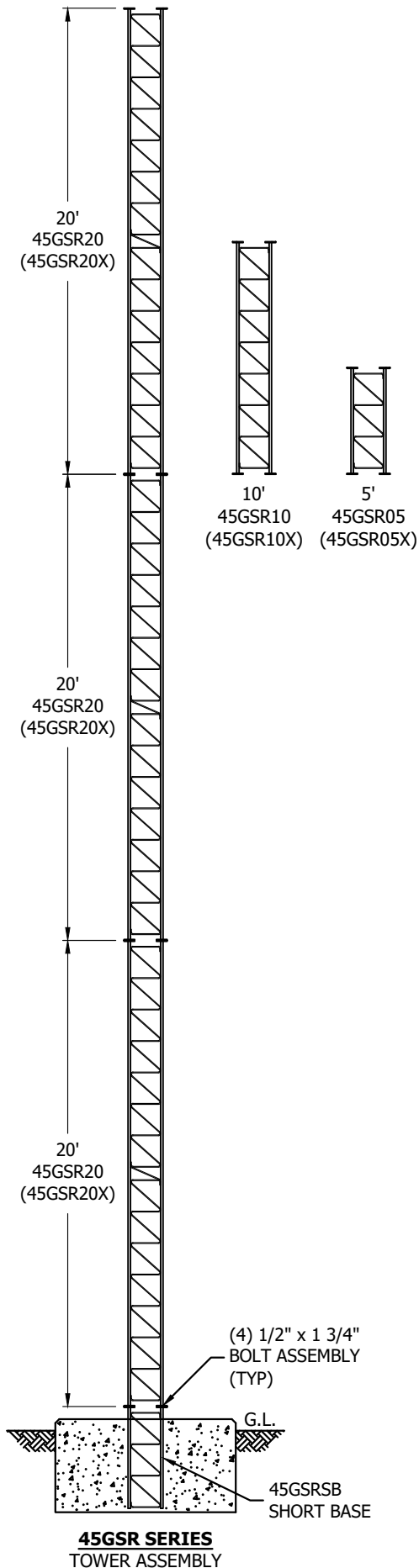

60' - 45SR060 BILL OF MATERIALS			
ITEM	QTY	P/N	DESCRIPTION
1	3	45GSR20	SECTION ASSY 45GSR 20' 1.25"D
2	1	45GSRSB	BASE SHORT 4.29' 45GSR CONC.

55' - 45SR055 BILL OF MATERIALS			
ITEM	QTY	P/N	DESCRIPTION
1	1	45GSR05	SECTION ASSY 45GSR 5' 1.25"DIA
2	1	45GSR10	SECTION ASSY 45GSR 10' 1.25"DIA
3	2	45GSR20	SECTION ASSY 45GSR 20' 1.25"D
4	1	45GSRSB	BASE SHORT 4.29' 45GSR CONC.

50' - 45SR050 BILL OF MATERIALS			
ITEM	QTY	P/N	DESCRIPTION
1	1	45GSR10	SECTION ASSY 45GSR 10' 1.25"DIA
2	2	45GSR20	SECTION ASSY 45GSR 20' 1.25"D
3	1	45GSRSB	BASE SHORT 4.29' 45GSR CONC.

45' - 45SR045 BILL OF MATERIALS			
ITEM	QTY	P/N	DESCRIPTION
1	1	45GSR05	SECTION ASSY 45GSR 5' 1.25"DIA
2	2	45GSR20	SECTION ASSY 45GSR 20' 1.25"D
3	1	45GSRSB	BASE SHORT 4.29' 45GSR CONC.

40' - 45SR040 BILL OF MATERIALS			
ITEM	QTY	P/N	DESCRIPTION
1	2	45GSR20	SECTION ASSY 45GSR 20' 1.25"D
2	1	45GSRSB	BASE SHORT 4.29' 45GSR CONC.

35' - 45SR035 BILL OF MATERIALS			
ITEM	QTY	P/N	DESCRIPTION
1	1	45GSR05	SECTION ASSY 45GSR 5' 1.25"DIA
2	1	45GSR10	SECTION ASSY 45GSR 10' 1.25"DIA
3	1	45GSR20	SECTION ASSY 45GSR 20' 1.25"D
4	1	45GSRSB	BASE SHORT 4.29' 45GSR CONC.

30' - 45SR030 BILL OF MATERIALS			
ITEM	QTY	P/N	DESCRIPTION
1	1	45GSR10	SECTION ASSY 45GSR 10' 1.25"DIA
2	1	45GSR20	SECTION ASSY 45GSR 20' 1.25"D
3	1	45GSRSB	BASE SHORT 4.29' 45GSR CONC.

20' - 45SR020 BILL OF MATERIALS			
ITEM	QTY	P/N	DESCRIPTION
1	1	45GSR20	SECTION ASSY 45GSR 20' 1.25"D
2	1	45GSRSB	BASE SHORT 4.29' 45GSR CONC.

10' - 45SR010 BILL OF MATERIALS			
ITEM	QTY	P/N	DESCRIPTION
1	1	45GSR10	SECTION ASSY 45GSR 10' 1.25"DIA
2	1	45GSRSB	BASE SHORT 4.29' 45GSR CONC.

GENERAL NOTES

1. THE SUITABILITY OF THE TABULATED TOWER DESIGN CRITERIA FOR A SPECIFIC APPLICATION MUST BE VERIFIED PRIOR TO INSTALLATION BY THE PURCHASER BASED ON SITE-SPECIFIC DATA AND THE INTENDED USE OF THE STRUCTURE.
2. ALL USERS ARE SOLELY RESPONSIBLE FOR THE INSTALLATION, USE, MAINTENANCE, INSPECTION, CONDITION ASSESSMENTS AND OTHER WORK TO BE PERFORMED IN COMPLIANCE WITH ALL APPLICABLE INDUSTRY, LOCAL, STATE AND FEDERAL REQUIREMENTS.
3. THE FOLLOWING MATERIAL SPECIFICATIONS APPLY TO THE TOWER DESIGN:
 LEG SIZE: Ø1-1/4" SOLID ROD 50 KSI MINIMUM YIELD STRENGTH
 BRACE SIZE: Ø7/16" SOLID ROD 36 KSI MINIMUM YIELD STRENGTH
 STRUCTURAL STEEL: 50 KSI MINIMUM YIELD STRENGTH
 FASTENERS: 120 KSI MINIMUM TENSILE STRENGTH
 GALVANIZED: ASTM A123
4. TOWER FABRICATION SHALL BE BY ROHN PRODUCTS, LLC, CERTIFIED AISC FABRICATOR.
5. THE TOWER DESIGN ASSUMES INSTALLATION ON A PROPERLY DRAINED LEVEL SITE. THE TOWER DESIGN MAY REQUIRE MODIFICATIONS FOR INSTALLATIONS ON SITES WITH A SLOPING GRADE OR FOR TOWERS SUPPORTED ON OTHER STRUCTURES.
6. INITIAL CONSTRUCTION INSPECTION REQUIREMENTS SHALL BE DETERMINED AND PERFORMED BY THE PURCHASER BASED ON THE LOCATION AND USE OF THE STRUCTURE.
7. SAFETY, STRENGTH AND STABILITY REQUIREMENTS FOR THE STRUCTURE FOR CONSTRUCTION AND MAINTENANCE ACTIVITIES SHALL BE IN ACCORDANCE WITH ANSI/ASSE A10.48, "CRITERIA FOR SAFETY PRACTICES WITH THE CONSTRUCTION, DEMOLITION, MODIFICATION AND MAINTENANCE OF COMMUNICATION STRUCTURES" AND ALL APPLICABLE INDUSTRY, LOCAL, STATE AND FEDERAL REGULATIONS AND STANDARDS.
8. ALL RIGGING, SAFETY EQUIPMENT AND TEMPORARY SUPPORTS REQUIRED FOR CONSTRUCTION AND MAINTENANCE SHALL BE DETERMINED, FURNISHED AND INSTALLED BY THE CONTRACTOR BASED ON THE MEANS AND METHODS CHOSEN BY THE CONTRACTOR. ALL CONSTRUCTION AND MAINTENANCE ACTIVITIES SHALL BE PERFORMED BY COMPETENT, QUALIFIED AND TRAINED PERSONNEL.
9. FIELD CONNECTIONS SHALL BE BOLTED. NO FIELD WELDING SHALL BE ALLOWED.
10. UNLESS OTHERWISE SPECIFIED, BOLTS SHALL BE TIGHTENED TO A "SNUG TIGHT" CONDITION WITH A NUT-LOCKING DEVICE WITH NO MINIMUM INSTALLED BOLT TENSION OR TORQUE VALUES REQUIRED.
11. A SAFETY CLIMB SYSTEM SHALL BE USED. ALL CLIMBING FACILITIES, INCLUDING SAFETY CLIMB SYSTEMS, SHALL BE INSPECTED PRIOR TO EACH USE.
12. PURCHASER SHALL VERIFY THAT THE INSTALLATION IS IN CONFORMANCE WITH ALL APPLICABLE INDUSTRY, LOCAL, STATE, AND FEDERAL REQUIREMENTS FOR GROUNDING AND OBSTRUCTION MARKING.
13. MAINTENANCE AND CONDITION ASSESSMENTS SHALL BE PERFORMED OVER THE LIFE OF THE STRUCTURE.
14. FOUNDATIONS SHALL BE DESIGNED TO SUPPORT THE CONDITIONS EXISTING AT THE SITE.

FILE NO.				
REVISIONS				
REV.	DESCRIPTION	DWN	CHK	APP
1	ADDED BILL OF MATERIALS	JHY	JDM	SY
DATE: 10/04/2023				



PO BOX 5999
 PEORIA, IL 61601-5999
 TOLL FREE 800-727-ROHN

THIS DRAWING IS THE PROPERTY OF ROHN. IT IS NOT TO BE REPRODUCED, COPIED OR TRACED IN WHOLE OR IN PART WITHOUT OUR WRITTEN CONSENT.

**45GSR SERIES TOWER ASSEMBLY
 10'-60'**

DWN: JHY	CHK'D: JDM	DATE: 01/09/2013
ENG'R: HA	SHEET #: 1 OF 1	
PRJ. ENG'R: JPK	PRJ. MANG'R:	
DRAWING NO: 45GSR	REV: 1	

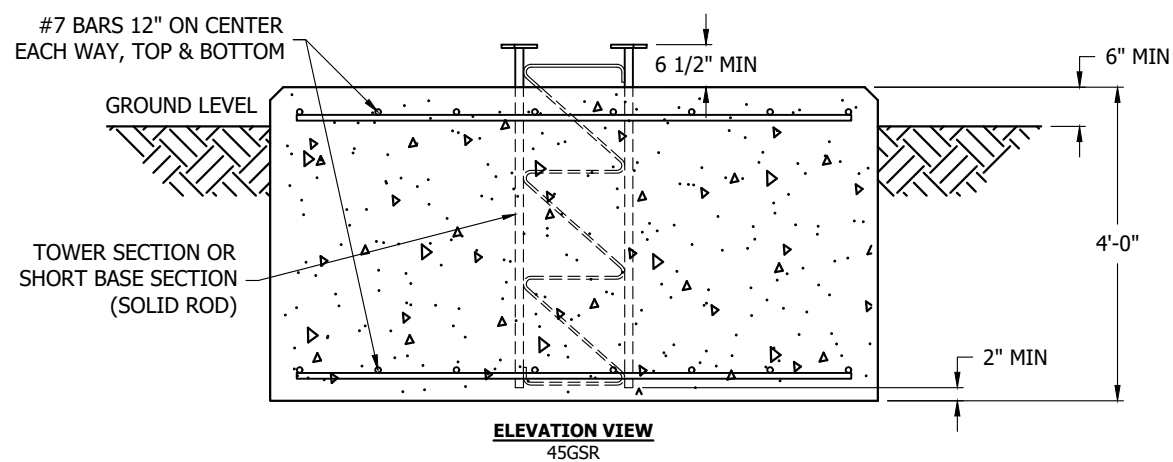
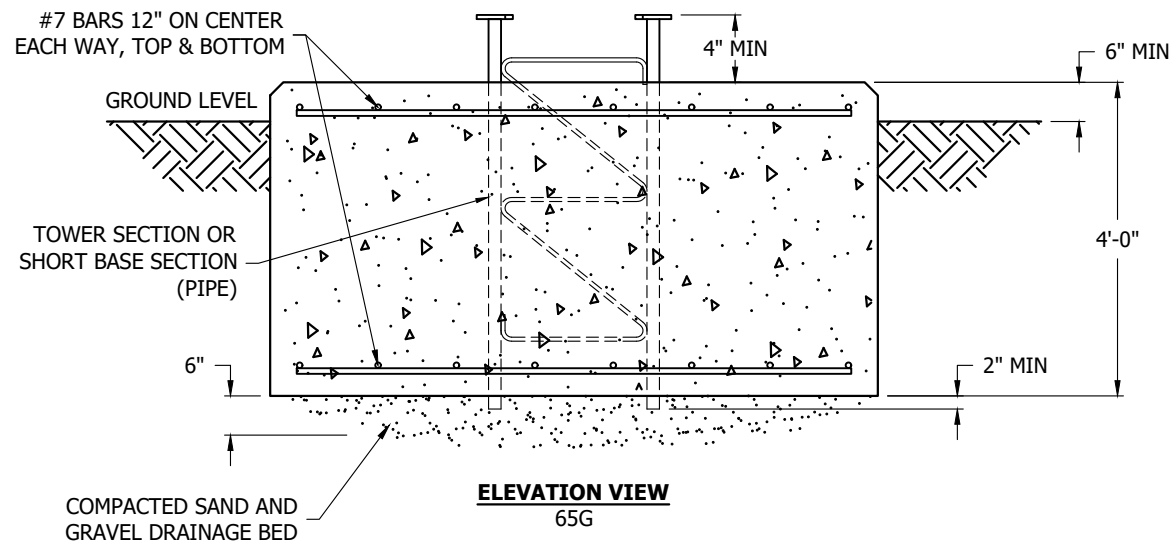
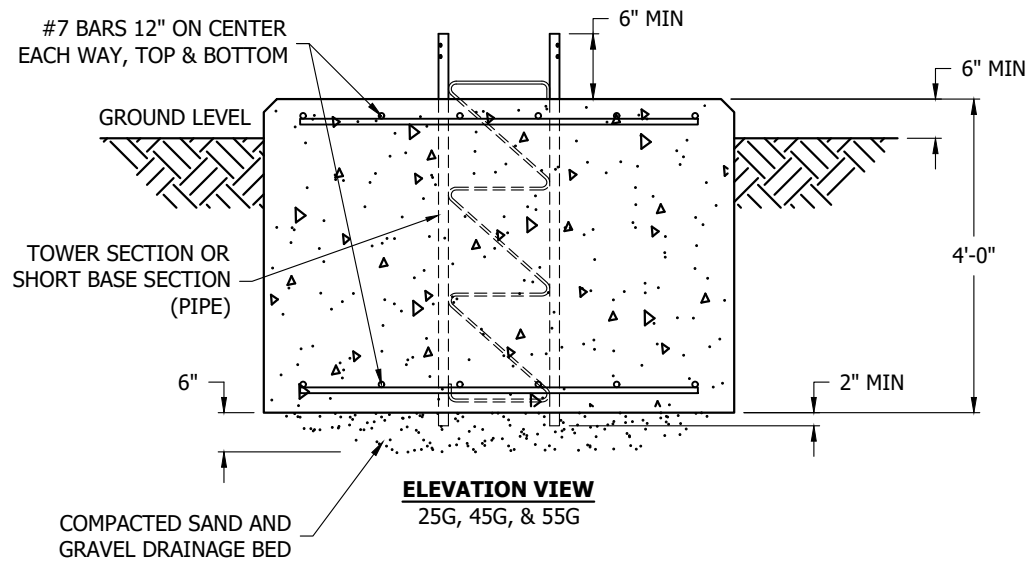

FOUNDATION DETAILS				
TOWER NUMBER	OVER-TURNING MOMENT (FT-LBS)	TOTAL SHEAR (LBS)	MAT WIDTH "W"	CONCRETE VOLUME (CU. YDS.)
25G	7000	510	4'-0"	2.4
45G	12300	1000	5'-3"	4.1
55G	22100	1600	6'-0"	5.3
65G/45GSR	53100	3500	7'-9"	8.9

GENERAL NOTES:
 1. FOR 25G, 45G, 55G, 65G, AND 45GSR TOWER ASSEMBLY DRAWINGS AND MAXIMUM TOWER HEIGHTS, REFER TO DRAWING NUMBER 25GSS, 45GSS, 55GSS, 65GSS, AND 45GSR RESPECTIVELY.

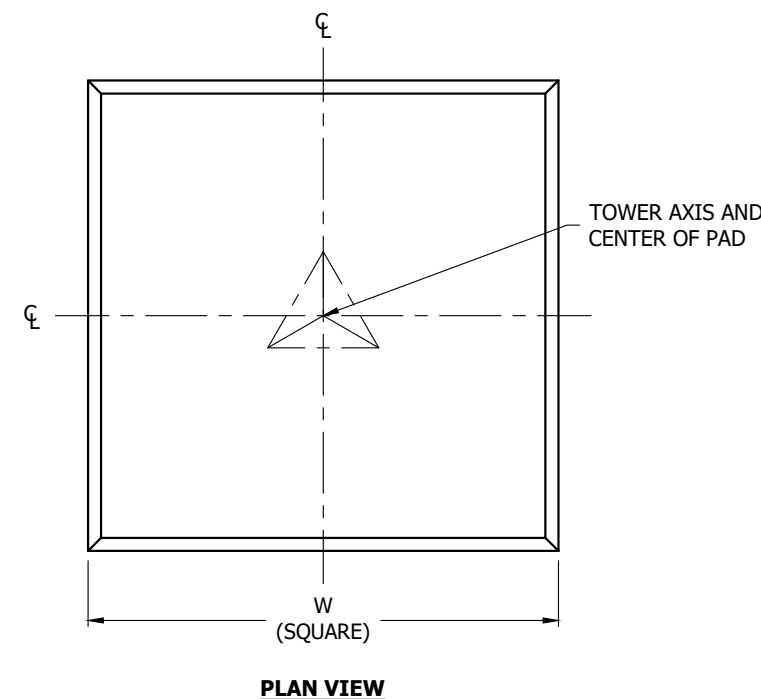

FILE NO. ROHN				
REVISIONS				
REV.	DESCRIPTION	DWN	CHK	APP

ROHN[®]
 PRODUCTS LLC
 PO BOX 5999
 PEORIA, IL 61601-5999
 TOLL FREE 800-727-ROHN

THIS DRAWING IS THE PROPERTY OF ROHN. IT IS NOT TO BE REPRODUCED, COPIED OR TRACED IN WHOLE OR IN PART WITHOUT OUR WRITTEN CONSENT.

G SERIES MAT FOUNDATION

DWN: JHY	CHK'D: JDM	DATE: 10/02/2023
ENG'R: SY	SHEET #: 1 OF 1	
PRJ. ENG'R: JTS	PRJ. MANG'R:	
DRAWING NO: GS-CAT-FND	REV: 0	

FOUNDATION AND ANCHOR TOLERANCES

ALL FOUNDATIONS

1. CONCRETE DIMENSIONS: PLUS OR MINUS 1" (25mm)
2. DEPTH OF FOUNDATION: PLUS 3" (76mm) OR MINUS 0"
3. DRILLED FOUNDATIONS OUT OF PLUMB: 1.0°
4. REINFORCING STEEL PLACEMENT: PER A.C.I. 301
5. PROJECTION OF EMBEDMENTS: PLUS OR MINUS 1/8" (3mm)
6. VERTICAL EMBEDMENTS OUT OF PLUMB: 0.5°

ANCHOR BOLTS

7. MAXIMUM DISTANCE FROM CENTERLINE OF ANCHOR BOLTS TO CENTERLINE OF FOUNDATION: 1/24 OF PIER DIAMETER UP TO A MAXIMUM OF 2" (51mm)
8. ANCHOR BOLT SPACING: 1/16" (2mm)
9. ANCHOR BOLT CIRCLE ORIENTATION: 0.25°
10. ANCHOR BOLT CIRCLE DIAMETER: PLUS OR MINUS 1/16" (2mm)

SELF-SUPPORTING TOWERS

11. FACE SPREAD DIMENSION CENTER TO CENTER OF ANCHOR BOLT CIRCLES: PLUS OR MINUS 1/16" (2mm) OR 1/16" (2mm) PER 20 FT. (6m) OF FACE SPREAD
12. MAXIMUM DIFFERENCE BETWEEN ANY TWO FOUNDATION ELEVATIONS: 1/2" (13mm)

GUYED TOWERS

13. GUY RADIUS: PLUS OR MINUS 5% OF DISTANCE SPECIFIED
14. ANCHOR ELEVATION: PLUS OR MINUS 5% OF GUY RADIUS
15. ANCHOR ALIGNMENT (PERPENDICULAR TO GUY RADIUS): 1.0°
16. ANCHOR ROD SLOPE: PLUS OR MINUS 1.0°
17. ANCHOR ROD ALIGNMENT WITH GUY RADIUS: PLUS OR MINUS 1.0°
18. ANCHOR HEAD OUT OF PLUMB: 1.0°
19. GUY INITIAL TENSION: PLUS OR MINUS 10% OF TENSION SPECIFIED

NOTE: TOLERANCES IN NOTES 13 AND 14 CAN NOT OCCUR SIMULTANEOUSLY.

FILE NO.

REVISIONS

REV	DESCRIPTION	DWN	CHK	APP
10	REMOVED WARNING TEXT DATE: 01/12/2017	MJH	JDM	HA



PO BOX 5999
PEORIA, IL 61601-5999
TOLL FREE 800-727-ROHN

THIS DRAWING IS THE PROPERTY OF ROHN. IT IS NOT TO BE REPRODUCED, COPIED OR TRACED IN WHOLE OR IN PART WITHOUT OUR WRITTEN CONSENT.

FOUNDATION & ANCHOR TOLERANCE

DWN: CSR	CHK'D: KTL	DATE: 09/25/1987	
ENGR: XK	SHEET #: 1 OF 1		
PRJ. ENGR:	PRJ. MANG'R:		
DRAWING NO: A810214		REV: 10	

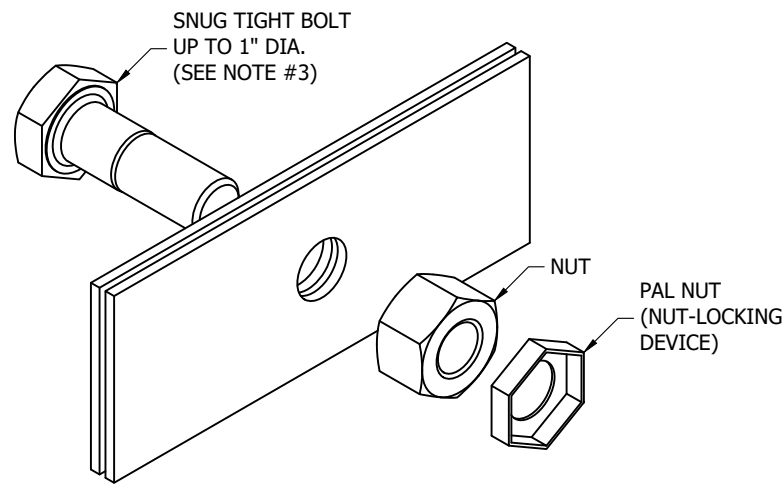

BOLT ASSEMBLY SUFFIX "GA"
(SNUG TIGHT BOLT, NUT, & PAL NUT)

REFER TO SHEET 2 FOR
NUT-LOCKING DEVICE OPTIONS

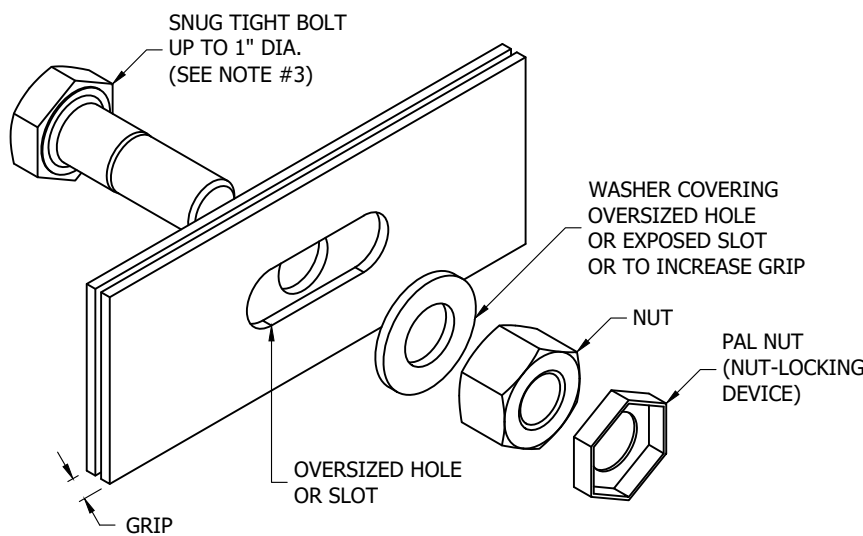

BOLT ASSEMBLY SUFFIX "GAW"
SLOT ON ONE SIDE OR NARROW GRIP
(SNUG TIGHT BOLT, WASHER, NUT, & PAL NUT)

**SNUG TIGHT BOLT
PAL NUT**

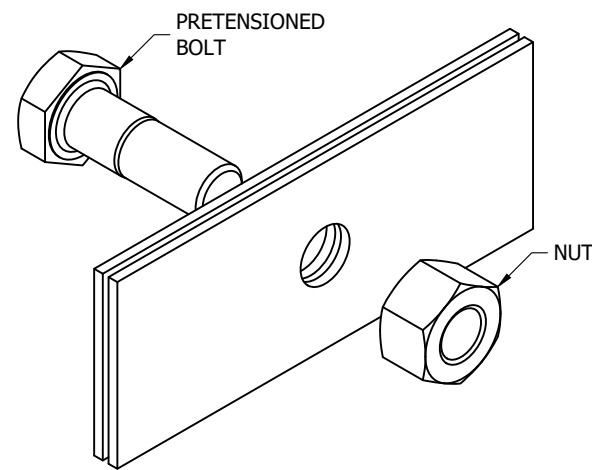

BOLT ASSEMBLY SUFFIX "GPT1"
(PRETENSIONED BOLT & NUT)

SHORTAGES OF NUT-LOCKING
DEVICES MAY OCCUR IF USED
ON PRETENSIONED BOLT
ASSEMBLIES.

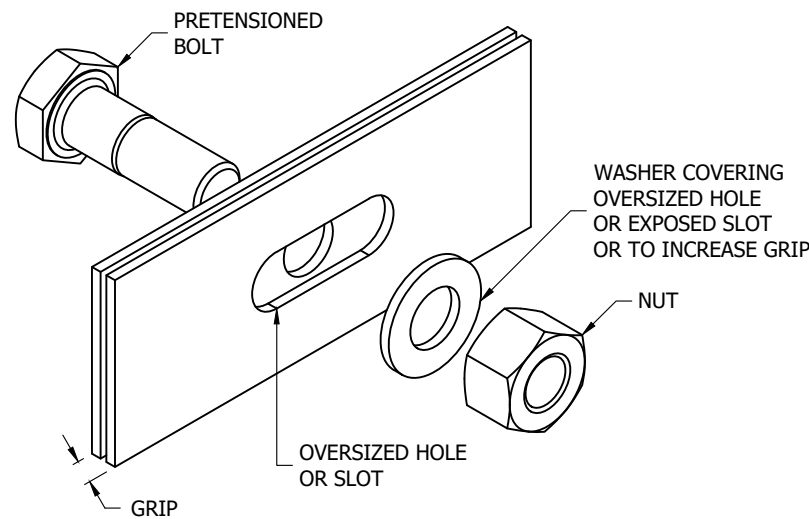

BOLT ASSEMBLY SUFFIX "GPT"
SLOT ON ONE SIDE OR NARROW GRIP
(PRETENSIONED BOLT, WASHER, & NUT)

PRETENSIONED BOLT

ROHN STANDARD BOLT ASSEMBLIES

1. ALL BOLTED CONNECTIONS ARE SNUG TIGHT CONNECTIONS UNLESS PRESTRESSED BOLTS ARE INDICATED ON AN ASSEMBLY DRAWING.
2. ROHN STANDARD BOLT ASSEMBLIES ARE ILLUSTRATED ON THE ADJACENT INSTALLATION DETAILS. WHEN SPECIFIED BY THE PURCHASER, OPTIONAL NUT-LOCKING DEVICES (TRI-LOC NUTS, ANCO NUTS, OR LOCK WASHERS) ARE PROVIDED AS A SUBSTITUTE FOR PAL NUTS FOR SNUG TIGHT CONNECTIONS (REFER TO SHEET 2 FOR INSTALLATION DETAILS).
3. TRI-LOC NUTS ARE PROVIDED AS STANDARD NUT-LOCKING DEVICES FOR SNUG TIGHT BOLTS GREATER THAN 1 INCH DIAMETER. ANCO NUTS ARE SUBSTITUTED FOR TRI-LOC NUTS WHEN SPECIFIED BY THE PURCHASER.
4. **PRETENSIONED BOLTS ARE PROVIDED AS AN ASSEMBLY INCLUDING THE BOLT, NUT AND REQUIRED WASHERS AND ARE TO BE USED, UNLESS OTHERWISE NOTED, FOR ALL DOUBLE ANGLE CONNECTIONS AND OTHER CONNECTIONS NOTED ON AN ASSEMBLY DRAWING. A NUT-LOCKING DEVICE IS NOT REQUIRED OR PROVIDED FOR PRETENSIONED BOLT ASSEMBLIES.**

WASHERS

5. WASHERS ARE PROVIDED TO COVER ALL OVERSIZED HOLES AND EXPOSED SLOTS. WHEN AN OVERSIZED HOLE OR EXPOSED SLOT IS PRESENT ON BOTH SIDES OF A CONNECTION, A WASHER IS REQUIRED UNDER THE BOLT HEAD AND THE NUT AND THE BOLT ASSEMBLY SUFFIX IN THE ASSEMBLY DRAWING BOM WILL INCLUDE AN ADDITIONAL "W".
6. WASHERS ARE ALSO PROVIDED TO INCREASE THE GRIP THICKNESS WHEN REQUIRED TO PREVENT THE NUT FROM BOTTOMING OUT ON THE BOLT THREADS.
7. **FOR SLOTTED GUSSET PLATE CONNECTIONS, WASHERS ARE ONLY REQUIRED FOR SINGLE ANGLE MEMBERS (SLOT EXPOSED ON ONE SIDE). WASHERS ARE NOT REQUIRED OR PROVIDED FOR DOUBLE ANGLE CONNECTIONS (SLOT IS NOT EXPOSED).**

SNUG TIGHT BOLT ASSEMBLY INSTALLATION

8. UNLESS OTHERWISE NOTED, BOLT ASSEMBLIES ARE TO BE TIGHTENED TO A SNUG TIGHT CONDITION (MEMBERS IN FIRM CONTACT USING AN ORDINARY WRENCH OR IMPACT WRENCH) AND SHALL INCLUDE A NUT-LOCKING DEVICE.
9. NO MINIMUM BOLT TENSIONS OR TORQUE VALUES ARE REQUIRED.
10. AFTER NUTS ARE TIGHT, PAL NUTS ARE TO BE INSTALLED WITH THE EDGE LIP OUT (SEE ADJACENT INSTALLATION DETAILS).
11. WHEN LOCK WASHERS ARE SUBSTITUTED FOR PAL NUTS, REPLACE ANY DAMAGED LOCK WASHERS DUE TO OVERTIGHTENING.

PRETENSIONED BOLT ASSEMBLY INSTALLATION

12. PRETENSIONED BOLT ASSEMBLIES, UNLESS OTHERWISE NOTED, SHALL BE TIGHTENED IN ACCORDANCE WITH THE AISC TURN-OF-NUT PRETENSIONING METHOD USING THE FOLLOWING NUT ROTATIONS FROM THE SNUG TIGHT CONDITION: 1/3 TURN FOR BOLT LENGTHS UP TO 4 TIMES THEIR DIAMETER AND 1/2 TURN FOR LONGER BOLTS.
13. LOCK WASHERS SHALL NOT BE USED WITH PRETENSIONED BOLT ASSEMBLIES.

FILE NO.

REVISIONS				
REV.	DESCRIPTION	DWN	CHK	APP
9	ADDED BOLT ASSEMBLY VIEWS	JHY	JDM	HA
DATE: 11/11/2019				



PO BOX 5999
PEORIA, IL 61601-5999
TOLL FREE 800-727-ROHN

THIS DRAWING IS THE PROPERTY OF ROHN. IT IS NOT TO BE REPRODUCED, COPIED OR TRACED IN WHOLE OR IN PART WITHOUT OUR WRITTEN CONSENT.

ROHN STANDARD
BOLT ASSEMBLY INSTALLATIONS

DWN:	OH	CHK'D:	GHB	DATE:	07/05/1979
ENGR:	TWS	SHEET #:	1 OF 2		
PRJ. ENGR:		PRJ. MANG'R:			
DRAWING NO:	A790135			REV:	9

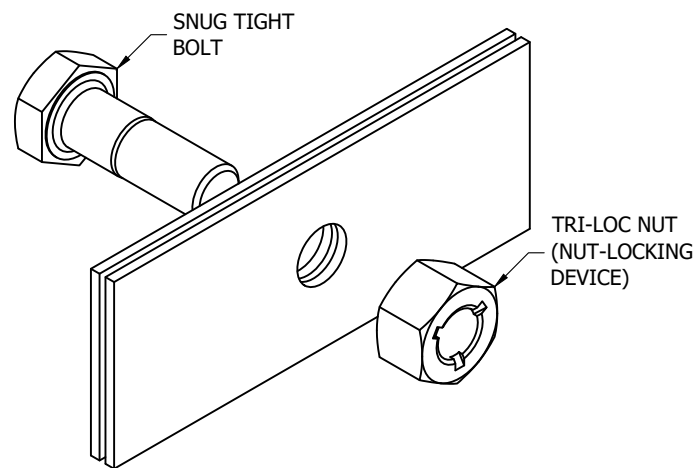

BOLT ASSEMBLY SUFFIX "GA-TLN"
(SNUG TIGHT BOLT & TRI-LOC NUT)

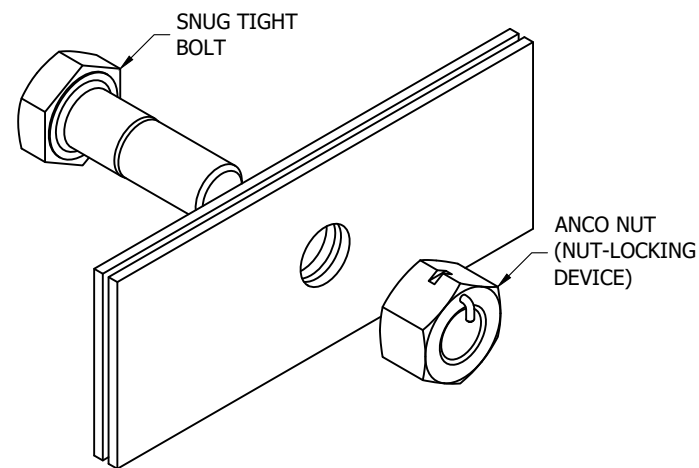

BOLT ASSEMBLY SUFFIX "GAAN"
(SNUG TIGHT BOLT & ANCO NUT)

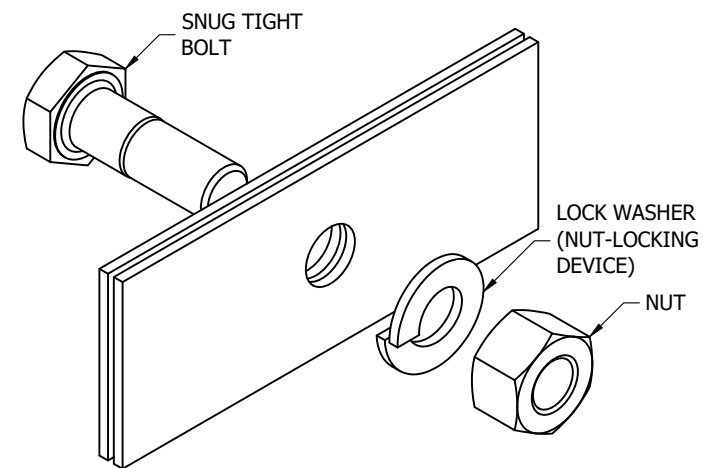

BOLT ASSEMBLY SUFFIX "GALW"
(SNUG TIGHT BOLT, LOCK WASHER, & NUT)

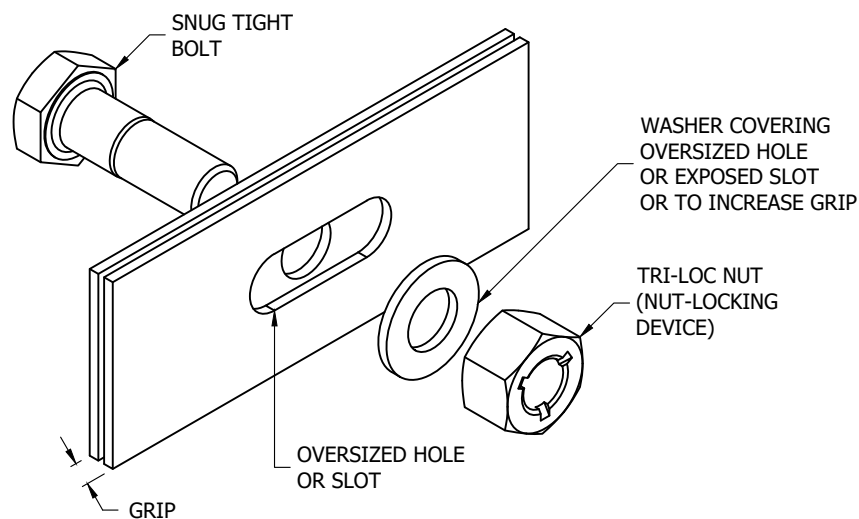

BOLT ASSEMBLY SUFFIX "GAW-TLN"
SLOT ON ONE SIDE OR NARROW GRIP
(SNUG TIGHT BOLT, WASHER, & TRI-LOC NUT)

**SNUG TIGHT BOLT
TRI-LOC NUT**

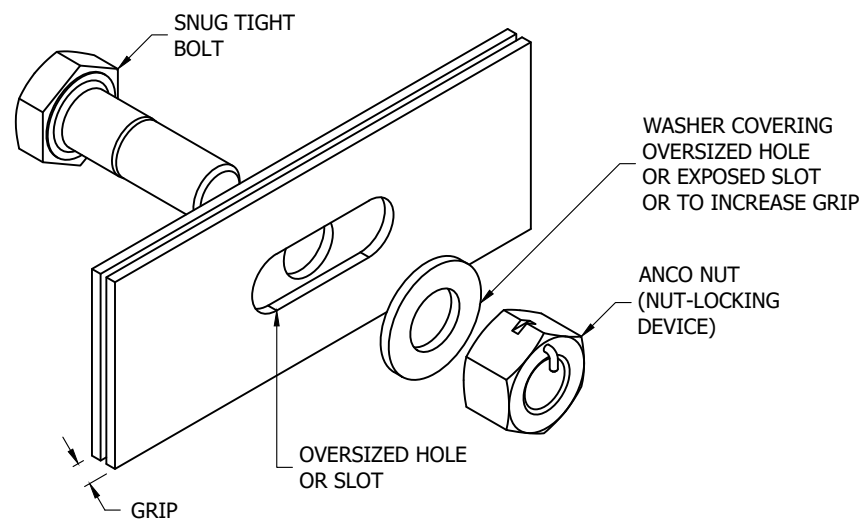

BOLT ASSEMBLY SUFFIX "GAWAN"
SLOT ON ONE SIDE OR NARROW GRIP
(SNUG TIGHT BOLT, WASHER, & ANCO NUT)

**SNUG TIGHT BOLT
ANCO NUT**

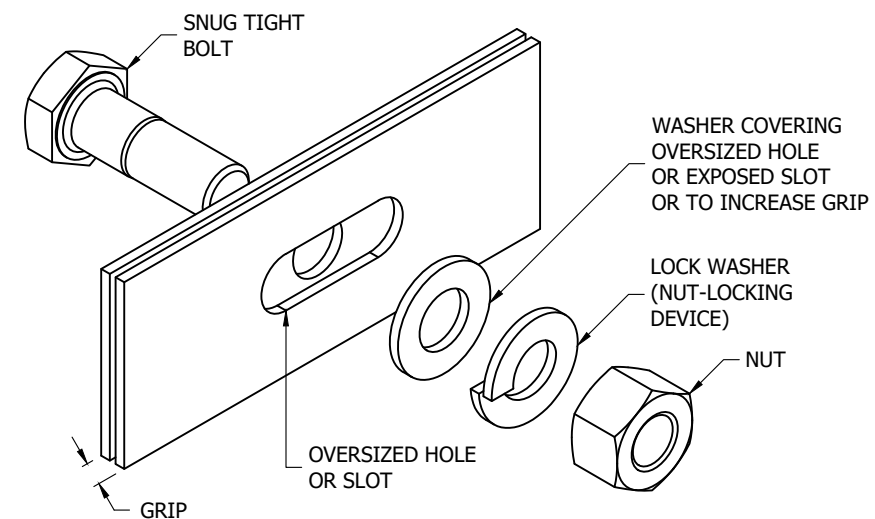

BOLT ASSEMBLY SUFFIX "GAWLW"
SLOT ON ONE SIDE OR NARROW GRIP
(SNUG TIGHT BOLT, WASHER, LOCK WASHER, & NUT)

**SNUG TIGHT BOLT
LOCK WASHER**

FILE NO.

REVISIONS				
REV.	DESCRIPTION	DWN	CHK	APP
9	ADDED BOLT ASSEMBLY VIEWS	JHY	JDM	HA
DATE: 11/11/2019				



PO BOX 5999
PEORIA, IL 61601-5999
TOLL FREE 800-727-ROHN

THIS DRAWING IS THE PROPERTY OF ROHN. IT IS NOT TO BE REPRODUCED, COPIED OR TRACED IN WHOLE OR IN PART WITHOUT OUR WRITTEN CONSENT.

ROHN STANDARD
BOLT ASSEMBLY INSTALLATIONS

DWN:	OH	CHK'D:	GHB	DATE:	07/05/1979
ENGR:	TWS	SHEET #:	2 OF 2		
PRJ. ENGR:		PRJ. MANG'R:			
DRAWING NO:	A790135			REV:	9